MACHINE REQUIREMENT LIST

(ELECTRICAL, HYDRAULIC, LUBRICATION, PNEUMATIC & LIFTING)

CAUTION!

It is important that the end user verifies actual transformer size, wire size, and local electrical code requirements before installing or supplying power to the machine.

The attached information is based on Mazak standard machine specification.

Technical Notes:

1. Items shown are for standard machines only. Please consult with the regional Mazak Technical Center, Service Center, or Mazak Engineering for information about machines with optional equipment (i.e. powerful coolant, air blast, large capacity tool magazine, multiple pallet changers, etc.).
2. Due to manufacturing and supplier specification changes, the main transformer may have a higher kVA rating than required by the standard machine. The wire sizes shown represent the wiring requirements for standard machines with a matching transformer.

NOTE:

Step-down or voltage regulating transformers are external (peripheral) to the machine tool and are considered the primary input line (source) for the machine. Local electrical code or practice may require a circuit breaker or other switching device for the isolation of electrical power when this type of transformer is used. In such cases, the machine tool end user is required to supply the necessary circuit breaker or switching device.

WARNING!

FAILURE TO COMPLY CAN RESULT IN PERSONAL INJURY AND DAMAGE TO THE MACHINE.

1 VC-Ez 16x (Smooth Ez5)

1-1 Power

Model	Spindle	Rating	30 Tool	50 Tool	Breaker Rating
VC-Ez 16x	12,000 min-1	30 min	22.44 kVA	22.94 kVA	40 kVA
		Cont.	17.37 kVA	17.87 kVA	
	15,000 min-1	30 min	22.71 kVA	23.21 kVA	65 kVA
		Cont.	17.60 kVA	18.10 kVA	

MAIN BREAKER MODEL	AC200v to AC230v input voltage	Max Rating
12,000 min-1	NF125-SVU-3P-100AL1-SHT	40 kVA
15,000 min-1	NF250-SVU-3P-175A-SHT	65 kVA

1-2 Air

PRESSURE			PSI (Mpa)	73-143 (.5-1.0)	
SPINDLE COOLING TYPE				SPINDLE AIR COOLING	SPINDLE LIQUID COOLING
SPINDLE TYPE	12,000 min-1 Grease Packed	Constant Consumption	cu.ft/min-ANR (L/min - ANR)	9.53 (270)	2.12 (60)
		Max Constant Consumption		13.07 (370)	5.65 (160)
	15,000 min-1 air/oil lubricated	Constant Consumption		15.54 (440)	8.12 (230)
		Max Constant Consumption		19.07 (540)	11.63 (330)

1-3 Coolant

In selection of coolant, confirm the following points with the coolant supplier:

1. Use water-soluble coolant liquid.

If oil-soluble coolant is used, coolant discharge rate drops and the coolant temperature excessively rises, and as a result, the machine becomes vulnerable to thermal deformation. Furthermore, oil-soluble coolant poses a risk of catching fire, and therefore its use requires measures to counter fire, such as the provision of an automatic fire extinguisher.

2. Consider lubricity, preservability and anti-foamability.
3. Confirm there is no adverse effect of coolant to human bodies.

Since water-soluble coolant may cause rashes to human bodies, good hygienic control must be directed to operators.

4. Confirm there is no hardening or inflating of rubber, resin and other chemical products.

Seals containing NBR (nitrile-butadiene rubber) as a main ingredient are used for this VCM Series. Some types of coolant contain an ingredient which may deteriorate NBR. Contact the coolant supplier and confirm no possibility of deteriorating NBR before using the selected coolant.

5. Confirm there is no problem of coolant mixture with recommended lubricant.

Rarely, coolant is discolored or solidified as a result of chemical reaction when it is mixed with lubricant.

Coolant tank capacity

Item	L(gal)
Standard specification	208 (55)
Option specification	360 (95)

c

1-4 Lubricant

Working Fluids and Lubricants to Be Prepared by Customers

No.	Lubrication Point	Q'ty	Recommended Oil	Remarks
1	Spindle cooling unit (option)	12 L (0.42 ft ³)	VELOCITE OIL No.3 (Mobil) Castrol Magna 2 (Castrol)	Change oil every year. Clean the filter at the same time.
2	Spindle BRG (Oil lubrication unit)	1.8L (0.06 ft ³)	Mobil DTE 24 (Mobil) Shell tellus S2 M 32 (Shell) Hispin aws 32 (Castrol)	Auto lubrication. Supply occasionally. Clean the filter every year.
β	Slideway (X, Y, Z) Ball screw	400 cm ³ (24.41 in ³) (grease)	<GREASE> CITRUX EP No.1 (Kyodo Yushi) Mobilux EP 1 (Mobil) Shell Gadus S2 V220_1 (Shell) Spheerol EPL 1 (Castrol)	Auto lubrication Cartridge type
4	ATC arm cam box	6 L (0.21 ft ³)	DELVAC 75W-90 (Mobil) (30T/50T)	Change oil every 6 months.
5	Tool clamp/unclamp (Air-hydro booster)	80ml	Mobil DTE 24 (Mobil) Shell tellus S2 M 32 (Shell) Hispin aws 32 (Castrol)	Change oil every year. Check occasionally.

Note : Use only recommended oil/lubricant to achieve the best performance and to prolong the machine's service life.

MAZAK is NOT responsible for any machine trouble, malfunction and/or accident caused by using oil other than those described above.

1-5 Rigging

Masses of machine units

Model	Unit	30 Tool Magazine	50 Tool Magazine
VC-Ez 16x	Machine Body (without Coolant Tank)	19200 lbs. (8700 kgs)	19840 lbs. (9000 kgs)
	Coolant Tank	330 lbs (150 kgs)	330 lbs (150 kgs)

Note : The figures indicated on the machine plates shall be applied if different from the manual.

Lifting

Lift the machine in the manner as shown below

- Firmly fix each structure with the fittings as shown below before lifting this machine.
- Use a dedicated lifting attachment as shown below
- Use sufficiently thick wire ropes with no slack or tears.
- Place wood blocks or pads between the machine and wire ropes so that the machine will not be damaged by direct contact of the wire ropes.
- When lifting the machine, pay attention so that the wire ropes will not touch the piping, hydraulic equipment, wiring, control equipment, and covers.
- Make sure that the drain ports of hydraulic oil tank, coolant tank, and lubricating oil tank are all securely tightened so that oil will not leak.
- When carrying the machine using rollers, pay attention so that impact will not be applied to the machine.

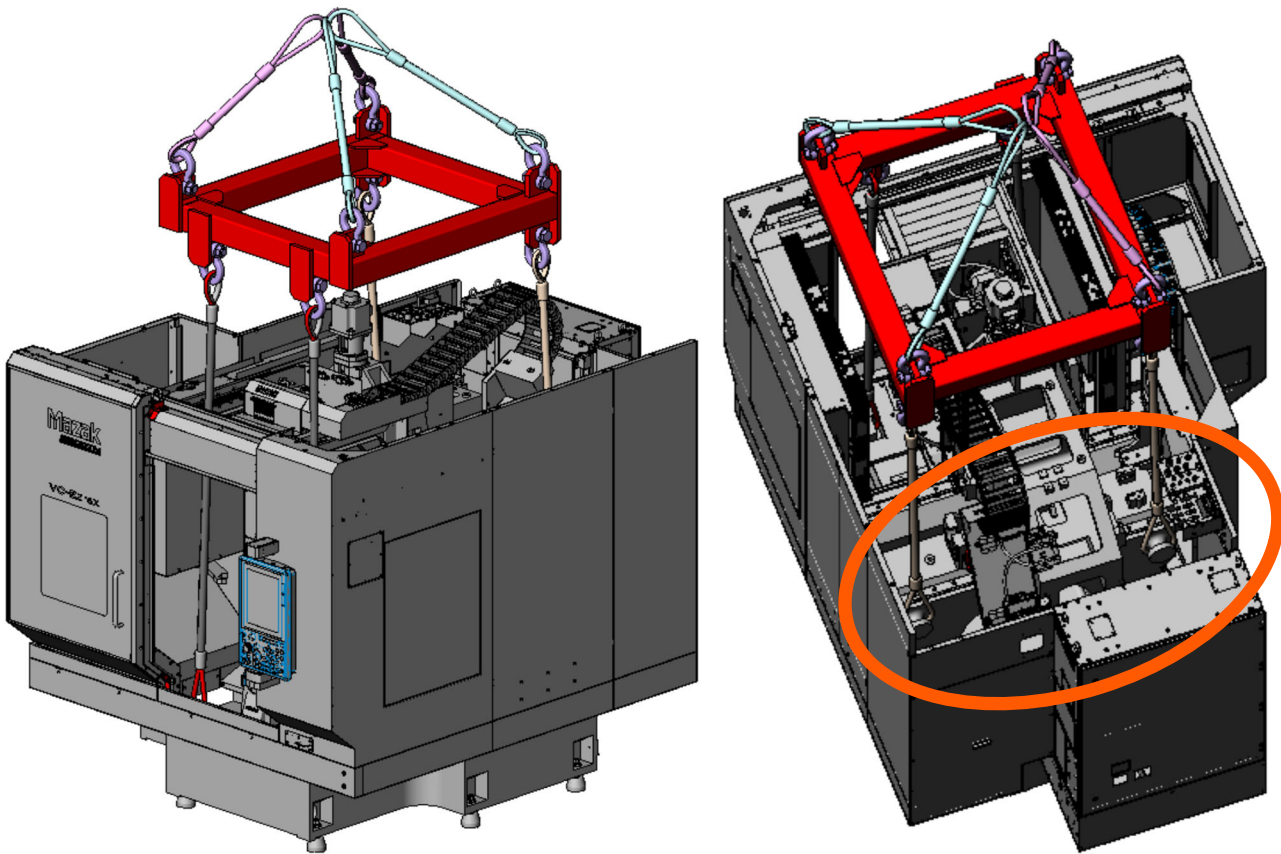

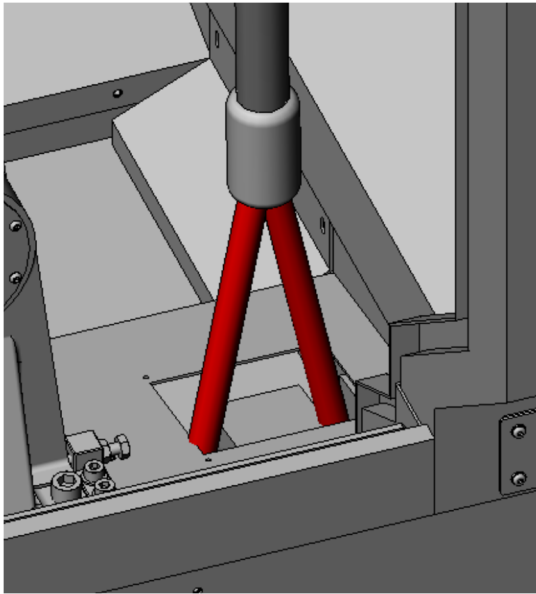
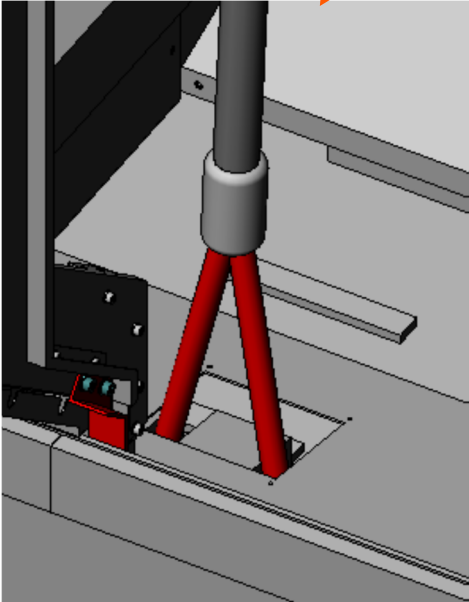
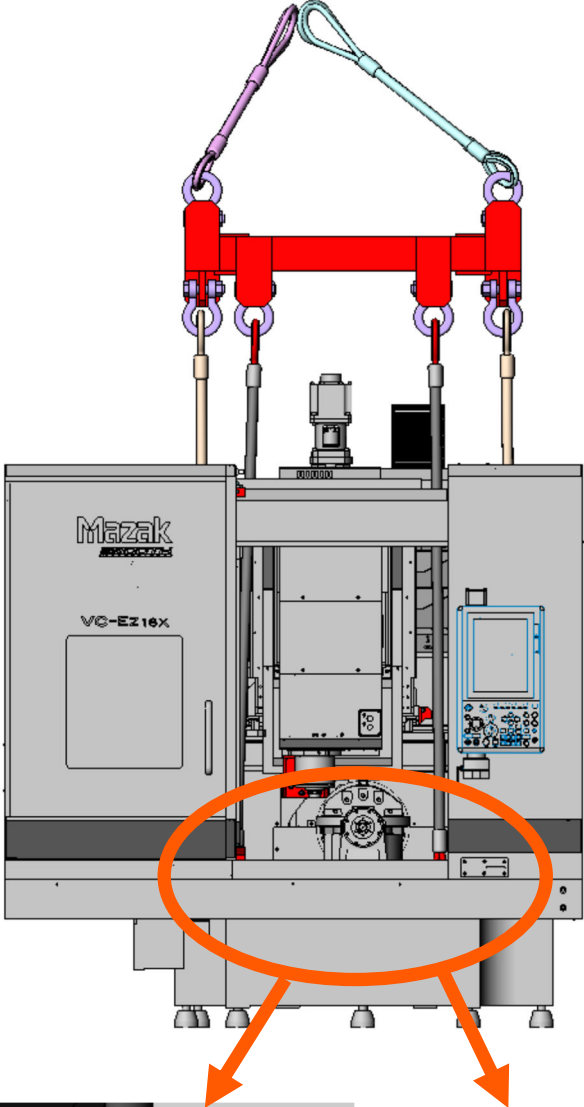

Unpacking, inspection, and cleaning

1. Removing the shipping brackets

The machine is shipped with its units fixed in place with shipping brackets so that they will not move during transportation. After installing the machine, remove all of shipping brackets. Store the removed shipping brackets and bolts in a suitable place to allow for reuse during movement or transport of the machine in the future.

Tools to be used: Hexagonal wrenches (6 mm and 10 mm)

